

KOBELCO

SK50SRX-7/SK58SRX-7

Performance  Design

SK50SRX SK58SRX

■ Bucket capacity:

SK50SRX 0.14 m³

SK58SRX 0.16 m³

■ Engine power:

29.1 kW / 2,400 min⁻¹

■ Operating weight:

SK50SRX 4,660–4,980 kg

SK58SRX 5,080–5,440 kg



Complies with the EU Stage V
exhaust emission regulation

We Save You Fuel
Achieving a Low-Carbon Society

Performance Design

Mini shovel SK50SRX/SK58SRX of KOBELCO has realised a completely new value by harmonising PERFORMANCE – greater efficiency and productivity with an increased power and speed and DESIGN – operator-based operability and comfort, refusing to accept any compromises. Its quality, which is undiminished by the mini excavator's size, is one of KOBELCO's answers to the question of the mini excavator's future.

KOBELCO continues its quest for innovation.





UNFORGETTABLE COMFORT

Our pursuit of functional beauty and aesthetic sense produced a new interior design.





Suspension seat

A proven Grammer suspension seat is fitted as standard, offering a reclining mechanism, shock absorber, and excellent seating comfort.

Wrist rest

The enlarged wrist rests keep the operator's forearms in a stable position, reducing fatigue during operation, and allowing stable operation.



Air conditioner

Additional air vents provide a uniform air flow in front of and behind the operator and direct the air flow onto the window, improving the defroster's dehumidification function.



Switches with LED backlights

The switches and dials have LED backlights – they provide a bright, clear view in the dark and set a luxurious mood.



Smartphone holder/ USB/AUX port

FUNCTIONAL WORK ENVIRONMENT

Realisation of the operator's convenience and comfort.



Colour monitor

A colour display with good readability comes as standard and shows various information such as operating history, maintenance cycle, and fuel and water temperature gauges. It can also be used to adjust the hydraulic oil flow to the attachments.



Hydraulic flow adjustment (Option)

Rotation or N&B piping flow can be selected from six preset types, or adjusted arbitrarily.



Engine start password

A password is required when starting the engine for greater security. The initial password must be set at our workshop.



Energy Conservation Mode

The SK50SRX/SK58SRX adapts S-mode which enables 26% (SK58SRX only) less fuel consumption compared with H-mode.



Auto deceleration switch

Auto deceleration switch installed as standard. Easy-to-use switch control.



Maintenance information



Operation history

Easy access

The shape of the access shutdown lever has been adapted and the door opens widely, offering excellent access.

Slide-open window

The window on the right side of the cab can be opened and closed both forwards and backwards to facilitate ventilation and make it easier to hear outside noise.



Lever angles allow for comfortable operations

The operator can move the levers horizontally without twisting their wrist, which reduces the fatigue caused by the operations.

Proportional hand control lever for rotation & N&B piping (Option)

Precise proportional controls are integrated into the joystick for ease of operation.



DAB+ radio
(FM/AM&AUX&Bluetooth*
& hands-free telephone)



Speaker



12V power outlet



Coat hook



Cup holder



LED door light



EXPERIENCING A COMPETENT PERFORMANCE

The new hydraulic system

Compared to previous models, the new hydraulic system is significantly improved, which thereby shortens the digging cycle time remarkably. It attains high performances without reducing the speed even when a heavy load is applied or when travelling on a slope.

By replacing the travel motor and swivel joint, the travel speed is increased.

>>> Travel speed

Faster by **12%** (SK58SRX)

Faster by **5%** (SK50SRX)

(Compared to previous models with two speeds)

>>> Hill-climbing speed

Faster by **10%** (SK58SRX)

(Compared to previous models)

By replacing the spool, the power loss is reduced, resulting in higher digging and swing speeds.

>>> Digging cycle time

Shortened by **11%** (SK58SRX)

Shortened by **4%** (SK50SRX)

(Compared to previous models)

Smoother operation

The new hydraulic system improves levelling performance and makes levelling work easier than with conventional machines when heavier attachments are installed.

Integrated-Flow Pump System

The instant the machine begins to dig, extra output from the third pump (which otherwise powers the swing and dozer circuit) is directed to the arm circuit and boom circuit (raise) for added power. This ensures fast and smooth arm and boom raising operation even under heavy loads.

Only SK58SRX.
SK50SRX does not
direct output from No.3
pump to the bucket.

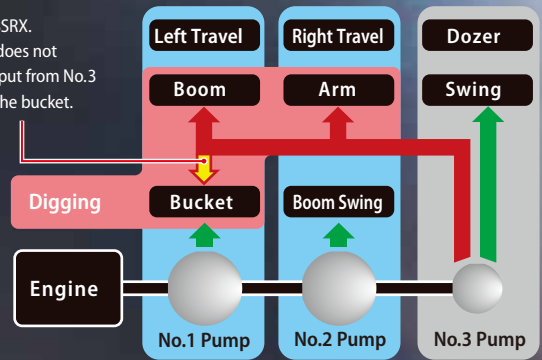

COMPACT, YET, BIG PERFORMANCE

Min. swing radius at boom swing
(SK50SRX (Cab) / SK58SRX with standard arm)

1,850 mm

*SK50SRX (Canopy) is 1,810 mm.



Short tail swing

The compact tail swing improves operating efficiency in limited space.

Tail overhang:

190 mm (290 mm)

Figure in () shows the value of with additional counterweight.



5,970 mm (SK50SRX)

6,460 mm (SK58SRX)

5,740 mm (SK50SRX)
6,100 mm (SK58SRX)

3,580 mm (SK50SRX)
4,120 mm (SK58SRX)

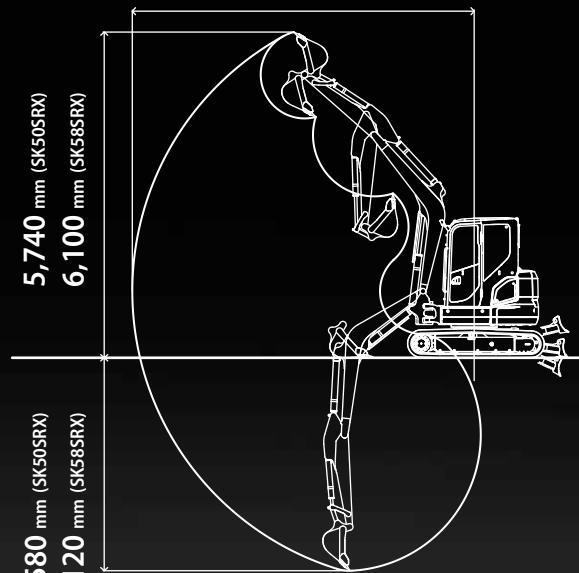

Figures above show the value for cab with long arm spec.

Wide working range

A larger boom and arm are provided as standard equipment to ensure a wide working range.

VERSATILITY



Easy hydraulic piping for quick hitch (Option)

Various attachments, such as the bucket, can be easily mounted and dismantled without leaving the cab, increasing working speed.



Dozer lever

The shape and angle of the dozer lever have been improved to make it easier to grip, and the first and second speed switches have been moved to the dozer lever to improve manoeuvrability when dozing. With the front dozer specification, functions can be switched on and off conveniently.



Dozer-blade shape

KOBELCO's unique blade design solves this problem by forming the earth into an arc that always falls forward. Because this prevents earth from falling behind the blade, only "one pass" is needed.



Angle dozer (Option)



Floating dozer (Option)

A floating dozer is fitted as optional equipment, contributing to easy levelling work.

RELIABLE CONSTRUCTION

The boom, arm and swing bracket all have large cross-section segments for added attachment strength.

Forged boom top

Boom cylinder guard

Plate type pin

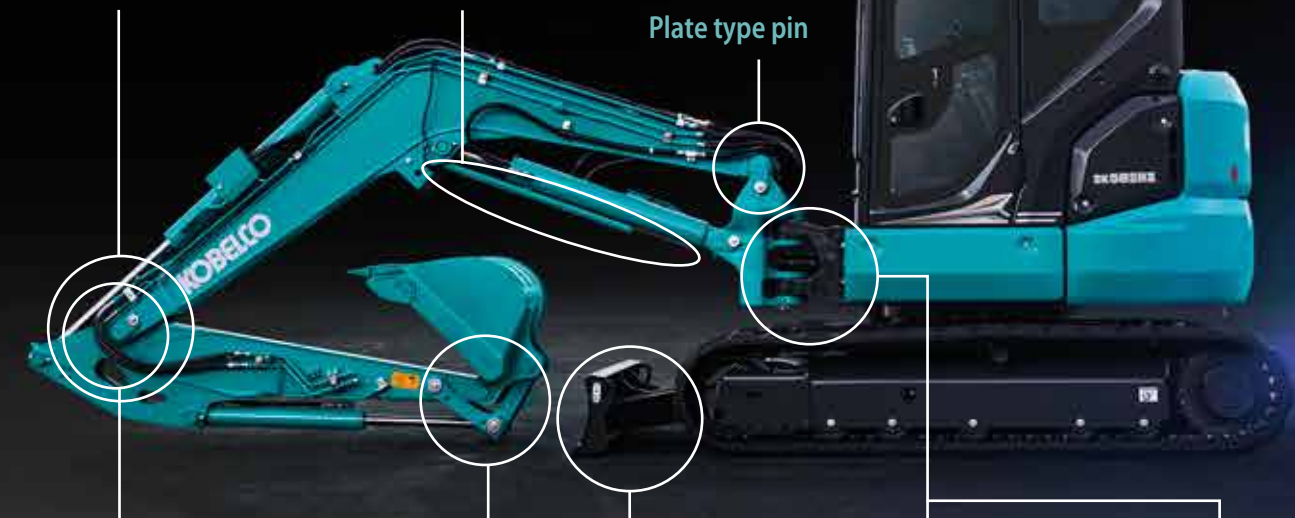

Bucket

Cast-iron idler link provides greater strength.



Dozer

Box construction dozer supports provide greater strength.



Swing bracket

Large, thick cast-iron swing bracket/front bracket.



Hydraulic hosing

The hydraulic hosing is housed inside the swing bracket.

Bolt-tightened pins

Bolt-tightened pins firmly lock the boom to prevent the boom top from opening laterally.

NON-STOP OPERATION BY iNDr

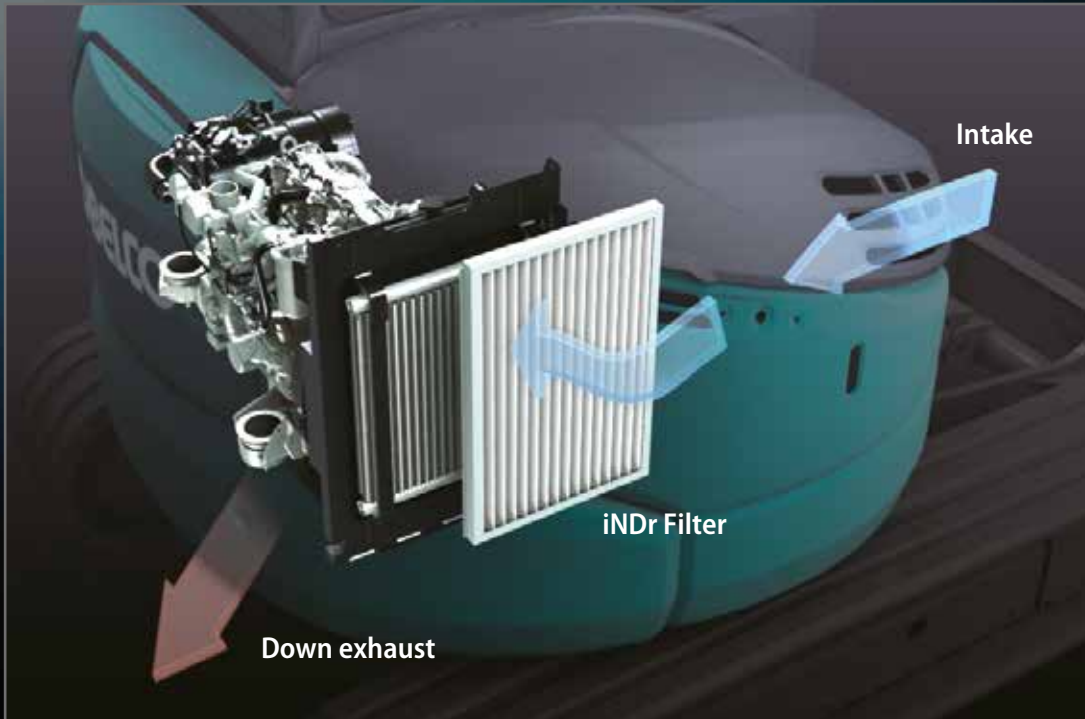

The offset duct slows down exhaust from the muffler and engine cooling fan.

Ultimate low noise

KOBELCO's exclusive iNDr Cooling System delivers amazingly quiet operation.

Sound Power Level

96 dB



iNDr+E

The iNDr+E system on the SK50SRX/SK58SRX features air intake at the front of the machine and air exhaust underneath. It functions in the same way as the iNDr system on the SR series machines, but also directs the muffler exhaust underneath.

The exhaust is further slowed down and cooled through the offset duct and then discharged into the atmosphere.

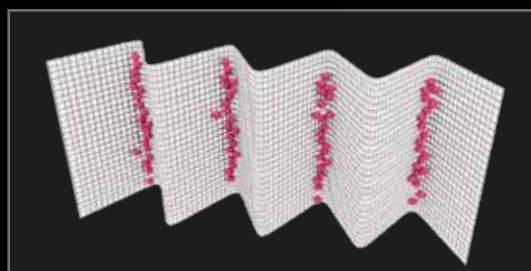

The iNDr filter has a high-density mesh of 30 lines per inch to collect dust.

EASY MAINTENANCE

Easy daily maintenance that saves the trouble of inspection and cleaning.



Easy Access to Component Inside the Cab



Hour meter



Air conditioner filter for outer air intake



Air conditioner filter for internal air circulation



Instruction manual storage box

Easy Access to Cooling Unit



iNDr filter

Laid out for easy access to radiator and cooling system.

Easy Access to Engine Compartment



① Pre fuel filter with built-in water separator

The position of the pre fuel filter has been changed to make it more accessible.



② Air cleaner



③ High-grade fuel filter

OPERATOR SAFETY



Reliable cab/canopy structure

The high-strength cab/canopy meets ROPS, TOPS and OPG Level 1 (Top guard) standards for greater operator safety.



LED work light

Work light is mounted under the boom to protect from damage.



Safety valve for boom cylinder (Option)



Safety valve for arm cylinder (Option)



Good visibility

The wiper mount has been moved to the upper right of the cab support and the skylight opening has been enlarged, improving visibility to the front and above.



Rear view mirror



Rear under mirror



Hammer for emergency exit



Accumulator for emergency attachment lowering

An installed accumulator allows the attachment to be safely lowered to the ground using in-cab controls in the event of an unexpected engine shut-down and class leading smooth operation.

Standard and Optional Equipment

● = Std ○ = Opt — = N/A

Category	Description	SK50SRX-7	SK58SRX-7
ENGINE	Auto deceleration	●	●
	Accelerator dial	●	●
	Energy Conservation Mode	●	●
	Engine start password	●	●
HYDRAULIC SYSTEM	N&B piping	●	●
	Rotation & N&B piping	○	○
	QH piping	○	○
	Foot control (for N&B piping)	●	●
	PHC (for N&B piping) with hydraulic flow adjustment	○	○
	PHC (for Rotation & N&B piping) with hydraulic flow adjustment	○	○
CABIN	Cab (ROPS/TOPS/OPG level 1)*	●	●
	Canopy (ROPS/TOPS/OPG level 1)*	○	○
	Front guard**	○	○
	Top guard**	○	○
	Suspension seat (Canopy: PVC / Cab: fabric)	●	●
	Retractable seatbelt	●	●
	Air conditioner**	●	●
	DAB+ radio (FM/AM & AUX & USB & Bluetooth* & hands free telephone)**	●	●
	Multi-function colour display	●	●
	Cup holder	●	●
	Smartphone holder**	●	●
	LED door light**	●	●
	USB/AUX port**	●	●
	12V power outlet	●	●
	Coat hook**	●	●
	Emergency exit hammer**	●	●
UNDERCARRIAGE	400 mm rubber shoe	●	●
	400 mm steel shoe	○	○
WORKING EQUIPMENT	Standard boom (2.71 m)	●	—
	Standard boom (2.99 m)	—	●
	Standard arm (1.55 m)	●	—
	Standard arm (1.69 m)	—	●
	Long arm (1.69 m)	○	—
	Long arm (1.92 m)	—	○
	Standard dozer	●	●
	Floating dozer	○	○
Angle dozer	○	○	
LIGHTS	LED working light on boom	●	●
	LED working light on Cab/Canopy	●	●
SAFETY EQUIPMENT	OHK (safety valve for boom & arm cylinder + lifting hook + overload alarm)	○	○
	Travel alarm	○	○
	Rear view mirror (left)	●	●
	Rear under mirror (rear right)	●	●
OTHERS	Standard counterweight	●	●
	Additional counterweight (+250 kg)	○	○
	Boom cylinder rod guard	●	●
	Arm & bucket cylinder rod guard	○	○
	Refuelling pump	○	○
	Hydraulic oil VG32	●	●
	Hydraulic oil VG46	○	○
	Hydraulic oil VG68	○	○
RAL color	○	○	

* ROPS (ISO 3471: 2008) / TOPS (ISO 12117: 1997) / OPG (ISO 10262: 1998)

** Only for Cab

Note: Figures in the above table show the value with standard arm (SK50SRX: 1.55 m, SK58SRX: 1.69 m) specs.

Regarding bucket capacity, 0.14 m³ in this catalogue is equivalent to 0.12 m³ in ISO07451 and 0.16 m³ in this catalogue is equivalent to 0.13 m³ in ISO0745.

The air conditioning system on this machine contains fluorinated greenhouse gas HFC-134a (GWP 1430). Quantity of gas 0.7 kg (CO₂ equivalent 0.9 t).

Bluetooth* is a registered trademark of the Bluetooth SIG Inc.

Specifications

Engine

Model	YANMAR 4TNV88C-PYBD
Type	Four-stroke, water-cooled, direct injection diesel engine, complies with EU Stage V exhaust emission regulation
No. of cylinders	4
Bore and stroke	88 mm x 90 mm
Displacement	2.189 L
Rated power output	27.7 kW/2,400 min ⁻¹ (ISO 9249: with fan)
	29.1 kW/2,400 min ⁻¹ (ISO 14396: without fan)
Max. torque	136.8 N·m/1,560 min ⁻¹ (ISO 9249: with fan)
	139.1 N·m/1,560 min ⁻¹ (ISO 14396: without fan)

Hydraulic system

Pump	
Type	Two variable displacement axial piston pumps + one gear pump + pilot pump
Max. discharge flow	SK50SRX 2 x 49.9 L/min 1 x 33.8 L/min 1 x 10.8 L/min
	SK58SRX 2 x 53 L/min 1 x 33.8 L/min 1 x 10.8 L/min
Relief valve setting	
Boom, arm and bucket	23.0 MPa
Travel circuit	23.0 MPa
Swing circuit	20.1 MPa
Blade circuit	22.0 MPa
Control circuit	3.5 MPa
Pilot control circuit	Gear type
Main control valves	11-spool
Oil cooler	Air cooled type

Swing system

Swing motor	One fixed displacement piston motor
Brake	Hydraulic; locking automatically when the swing control lever is in the neutral position
Parking brake	Wet multiple plate
Swing speed	8.5 min ⁻¹
Tail swing radius	1,170 mm
Swing torque	12.4 kN·m

Travel system

Travel motors	Two variable displacement piston motors	
Travel brakes	Hydraulic brake	
Parking brakes	Wet multiple plate	
Travel shoes	38 each side	
Travel speed	SK50SRX	4.2/2.2 km/h (rubber shoe) 3.9/2.1 km/h (steel shoe)
	SK58SRX	4.5/2.4 km/h (rubber shoe) 4.2/2.2 km/h (steel shoe)
Drawbar pulling force	SK50SRX	54.7 kN
	SK58SRX	54.5 kN
Gradeability	58% {30°}	

Cab & control

Cab	
All-weather, sound-suppressed steel cab mounted on the silicon-sealed viscous mounts and equipped with a heavy, insulated floor mat	
Control	
Two hand levers and two foot pedals for travel	
Two hand levers for excavating and swing	
Electric rotary-type engine throttle	
Foot control (for boom swing)	
Foot control (for N&B piping)	
Dozer lever	
Noise levels	
External	96 dB(A)
Operator	79 dB(A)

Boom, arm & bucket

Model	SK50SRX		SK58SRX	
	Cab	Canopy	Cab	Canopy
Boom cylinder	100 mm x 695 mm	100 mm x 702 mm	100 mm x 699 mm	
Arm cylinder	80 mm x 702 mm		90 mm x 716 mm	
Bucket cylinder	75 mm x 546 mm			
Swing cylinder	90 mm x 564 mm			

Dozer blade

Dozer cylinder	90 mm x 200 mm
Dimension	1,960 mm (width) x 345 mm (height)
Working range	465 mm (up) x 335 mm (down)

Refilling capacities & lubrications

Fuel tank	75 L
Cooling system	8.5 L
Engine oil	7.5 L
Travel reduction gear	2 x 0.8 L
Hydraulic oil tank	27.9 L tank oil level
	59 L hydraulic system



Working ranges

Unit: m

Model	SK50SRX				SK58SRX			
	Cab	Canopy	Cab	Canopy	Cab	Canopy	Cab	Canopy
Arm length	1.55 m	1.69 m	1.69 m	1.92 m				
a- Max. digging reach	5.85	5.97	6.24	6.46				
b- Max. digging reach at ground level	5.70	5.82	6.10	6.33				
c- Max. digging depth	3.44	3.58	3.89	4.12				
d- Max. digging height	5.66	5.75	5.74	5.83	5.95	6.10		
e- Max. dumping clearance	4.08	4.16	4.16	4.24	4.37	4.52		
f- Min. dumping clearance	1.51	1.56	1.37	1.42	1.59	1.36		
g- Max. vertical wall digging depth	2.82	2.93	3.12	3.35				
h- Min. swing radius at boom straight	2.25	2.21	2.26	2.22	2.25	2.27		
h'-Min. swing radius at boom swing	1.85	1.81	1.86	1.82	1.85	1.87		
i- Horizontal digging stroke at ground level	2.65	2.87	3.00	3.39				
j- Digging depth for 2.4 m (8') flat bottom	3.02	3.17	3.47	3.73				
k- Dozer blade (height/depth) (mm)	465/335							

*Figures in the above tables show the value with 0.14–0.16 m³ bucket. Regarding bucket capacity, 0.14 m³ in this catalogue is equivalent to 0.12 m³ in ISO07451 and 0.16 m³ in this catalogue is equivalent to 0.13 m³ in ISO0745.

Digging force (ISO 6015)

Unit: kN

Model	SK50SRX		SK58SRX	
Arm length	1.55 m	1.69 m	1.69 m	1.92 m
Bucket digging force	35.6			
Arm crowding force	20.9	19.7	24.8	22.5

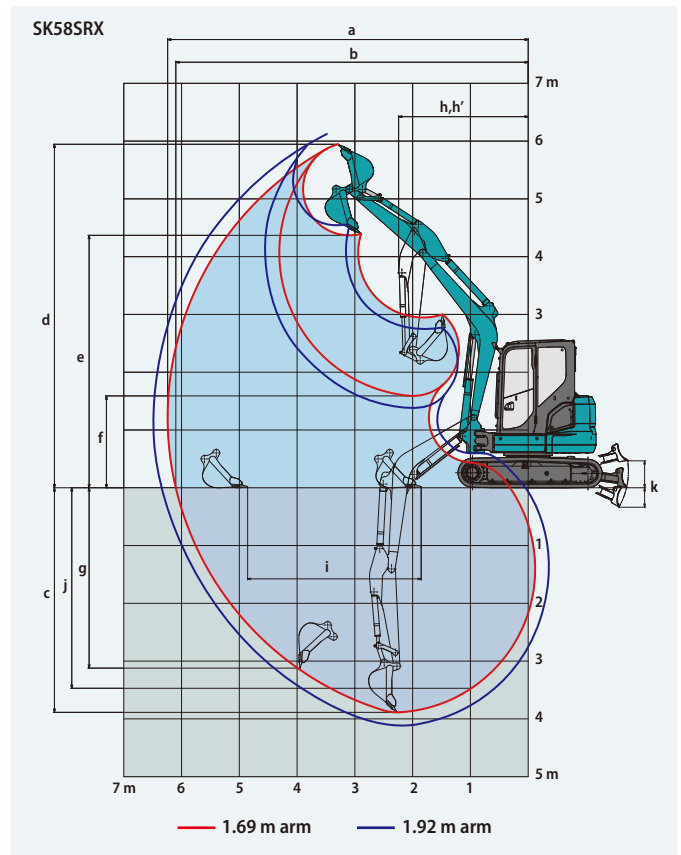

Dimensions

Unit: mm

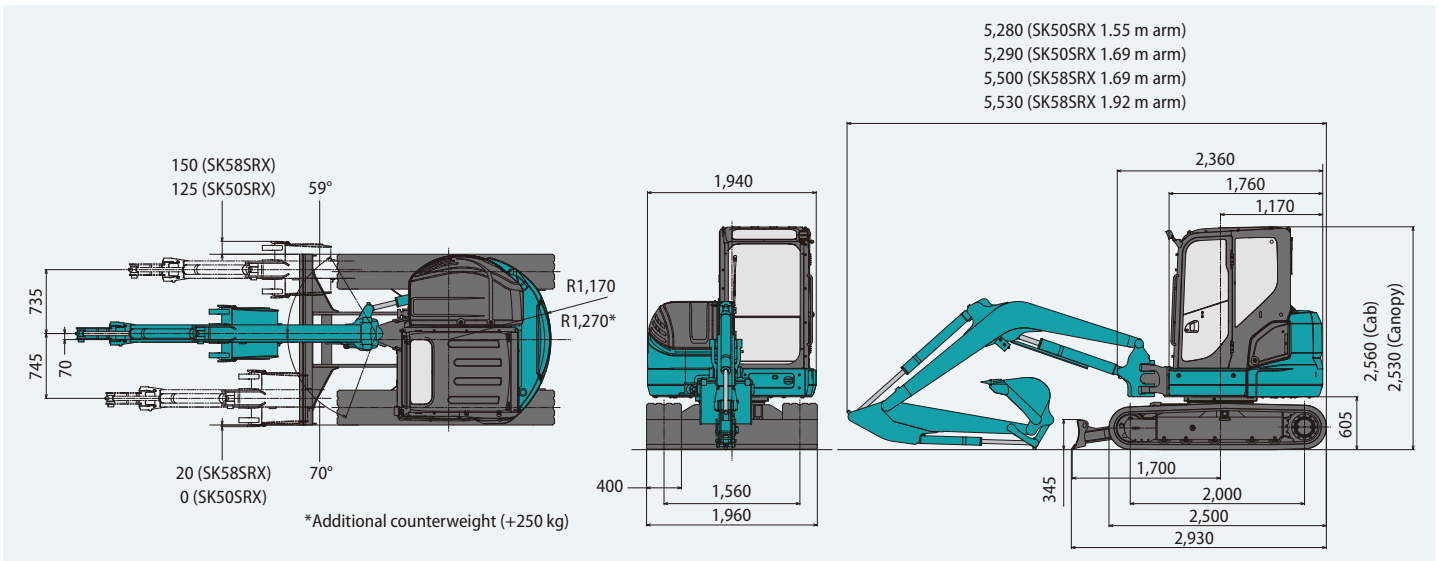

Operating weight & ground pressure

In standard trim, with standard boom, standard arm, and 0.14 m³ (100 kg) – 0.16 m³ (110 kg) bucket.

Model	SK50SRX				SK58SRX			
	Cab		Canopy		Cab		Canopy	
Shaped	Steel shoe	Rubber shoe	Steel shoe	Rubber shoe	Steel shoe	Rubber shoe	Steel shoe	Rubber shoe
Shoe width mm	400							
Overall width of crawler mm	1,960							
Ground pressure kPa	29.0	27.1	28.2	26.3	31.8	29.5	30.9	28.6
Operating weight kg	4,980	4,810	4,830	4,660	5,440	5,230	5,290	5,080

* Regarding bucket capacity, 0.14 m³ in this catalogue is equivalent to 0.12 m³ in ISO07451 and 0.16 m³ in this catalogue is equivalent to 0.13 m³ in ISO0745.

Lift capacities

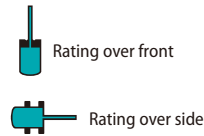
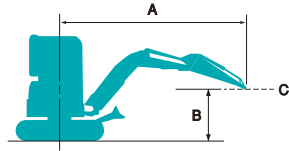

A: Reach from swing centreline to arm top
 B: Arm top height above/below ground
 C: Lift point
 Bucket: Without
 Dozer: Blade up
 Relief valve setting: 23.0 MPa

SK50SRX Canopy		Arm: 1.55 m		Standard counterweight		Rubber shoe: 400 mm								
B	A	1.0 m		2.0 m		3.0 m		4.0 m		5.0 m		At Max. Reach		Radius
		kg	kg	kg	kg	kg	kg	kg	kg	kg	kg	kg	kg	
4.0 m	kg											*860	850	3.97 m
3.0 m	kg					*1,170	*1,170	1,000	840			770	650	4.65 m
2.0 m	kg					1,530	1,250	960	810			680	570	4.98 m
1.0 m	kg					1,430	1,160	930	770	660	560	660	550	5.05 m
G.L.	kg			*1,390	*1,390	1,380	1,120	900	750			680	570	4.87 m
-1.0 m	kg	*2,020	*2,020	*2,700	2,170	1,380	1,110	900	740			790	660	4.41 m
-2.0 m	kg			2,970	2,230	1,410	1,140					1,120	920	3.51 m

SK50SRX Cab		Arm: 1.55 m		Standard counterweight		Rubber shoe: 400 mm									
B	A	1.0 m		2.0 m		3.0 m		4.0 m		5.0 m		At Max. Reach		Radius	
		kg	kg	kg	kg	kg	kg	kg	kg	kg	kg	kg	kg		
4.0 m	kg											*860	*860	3.97 m	
3.0 m	kg							*1,170	*1,170	1,040	870		*790	680	4.65 m
2.0 m	kg							1,590	1,300	1,010	840		710	600	4.98 m
1.0 m	kg							1,490	1,210	970	800	700	580	5.05 m	
G.L.	kg			*1,390	*1,390	1,440	1,160	940	780			710	600	4.87 m	
-1.0 m	kg	*2,020	*2,020	*2,700	2,260	1,440	1,160	940	780			820	680	4.41 m	
-2.0 m	kg			*2,990	2,320	1,480	1,190					1,170	960	3.51 m	

SK50SRX Canopy		Arm: 1.69 m		Standard counterweight		Rubber shoe: 400 mm								
B	A	1.0 m		2.0 m		3.0 m		4.0 m		5.0 m		At Max. Reach		Radius
		kg	kg	kg	kg	kg	kg	kg	kg	kg	kg	kg	kg	
5.0 m	kg											*1,020	*1,020	2.84 m
4.0 m	kg							*1,000	840			*780	*780	4.13 m
3.0 m	kg							1,000	840			*720	620	4.78 m
2.0 m	kg					1,540	1,260	970	810	680	570	660	550	5.10 m
1.0 m	kg					1,430	1,160	920	770	660	560	630	530	5.17 m
G.L.	kg			*1,420	*1,420	1,370	1,110	890	740			650	550	4.99 m
-1.0 m	kg	*1,870	*1,870	*2,560	2,140	1,370	1,100	890	730			750	620	4.55 m
-2.0 m	kg	*2,900	*2,900	2,940	2,200	1,400	1,130					1,020	840	3.69 m

SK50SRX Cab		Arm: 1.69 m		Standard counterweight		Rubber shoe: 400 mm									
B	A	1.0 m		2.0 m		3.0 m		4.0 m		5.0 m		At Max. Reach		Radius	
		kg	kg	kg	kg	kg	kg	kg	kg	kg	kg	kg	kg		
4.0 m	kg									*1,000	880		*780	*780	4.13 m
3.0 m	kg									1,040	870		*720	650	4.78 m
2.0 m	kg							1,600	1,310	1,010	840	710	600	690	5.10 m
1.0 m	kg							1,490	1,210	970	800	690	580	5.17 m	
G.L.	kg			*1,420	*1,420	1,440	1,160	940	770			680	570	4.99 m	
-1.0 m	kg	*1,870	*1,870	*2,560	2,240	1,430	1,150	930	770			780	650	4.55 m	
-2.0 m	kg	*2,900	*2,900	3,070	2,290	1,460	1,180					1,070	880	3.69 m	

SK50SRX Canopy		Arm: 1.55 m		Additional counterweight (+250 kg)		Rubber shoe: 400 mm									
B	A	1.0 m		2.0 m		3.0 m		4.0 m		5.0 m		At Max. Reach		Radius	
		kg	kg	kg	kg	kg	kg	kg	kg	kg	kg	kg	kg		
4.0 m	kg											*860	*860	3.97 m	
3.0 m	kg							*1,170	*1,170	1,140	960		*790	750	4.65 m
2.0 m	kg							*1,710	1,430	1,110	930		790	670	4.98 m
1.0 m	kg							1,640	1,340	1,070	890	770	640	5.05 m	
G.L.	kg			*1,390	*1,390	1,600	1,300	1,040	870			790	670	4.87 m	
-1.0 m	kg	*2,020	*2,020	*2,700	2,510	1,590	1,290	1,040	870			910	760	4.41 m	
-2.0 m	kg			*2,990	2,570	1,630	1,320					1,290	1,070	3.51 m	

SK50SRX Cab		Arm: 1.55 m		Additional counterweight (+250 kg)		Rubber shoe: 400 mm									
B	A	1.0 m		2.0 m		3.0 m		4.0 m		5.0 m		At Max. Reach		Radius	
		kg	kg	kg	kg	kg	kg	kg	kg	kg	kg	kg	kg		
4.0 m	kg											*860	*860	3.97 m	
3.0 m	kg							*1,170	*1,170	*1,160	990		*790	780	4.65 m
2.0 m	kg							*1,710	1,480	1,150	960		*790	690	4.98 m
1.0 m	kg							1,700	1,390	1,110	930	800	680	5.05 m	
G.L.	kg			*1,390	*1,390	1,660	1,350	1,080	900			820	690	4.87 m	
-1.0 m	kg	*2,020	*2,020	*2,700	2,600	1,660	1,340	1,080	900			950	790	4.41 m	
-2.0 m	kg			*2,990	2,660	1,690	1,370					1,340	1,110	3.51 m	

SK50SRX Canopy		Arm: 1.69 m		Additional counterweight (+250 kg)		Rubber shoe: 400 mm										
B	A	1.0 m		2.0 m		3.0 m		4.0 m		5.0 m		At Max. Reach		Radius		
		kg	kg	kg	kg	kg	kg	kg	kg	kg	kg	kg	kg			
5.0 m	kg											*1,020	*1,020	2.84 m		
4.0 m	kg							*1,000	970			*780	*780	4.13 m		
3.0 m	kg							*1,100	960			*720	*720	4.78 m		
2.0 m	kg							*1,610	1,440	1,110	930	780	660	*720	640	5.10 m
1.0 m	kg							1,640	1,340	1,070	890	770	650	730	620	5.17 m
G.L.	kg			*1,420	*1,420	1,590	1,290	1,040	860			760	640	4.99 m		
-1.0 m	kg	*1,870	*1,870	*2,560	2,480	1,580	1,280	1,030	860			870	730	4.55 m		
-2.0 m	kg	*2,900	*2,900	*3,240	2,540	1,610	1,310					1,180	980	3.69 m		

SK50SRX Cab		Arm: 1.69 m		Additional counterweight (+250 kg)		Rubber shoe: 400 mm										
B	A	1.0 m		2.0 m		3.0 m		4.0 m		5.0 m		At Max. Reach		Radius		
		kg	kg	kg	kg	kg	kg	kg	kg	kg	kg	kg	kg			
4.0 m	kg									*1,000	*1,000		*780	*780	4.13 m	
3.0 m	kg									*1,100	1,000		*720	*720	4.78 m	
2.0 m	kg							*1,610	1,490	1,150	960	810	690	*720	670	5.10 m
1.0 m	kg							*1,710	1,390	1,110	920	800	670	760	640	5.17 m
G.L.	kg			*1,420	*1,420	1,650	1,340	1,080	900			790	670	4.99 m		
-1.0 m	kg	*1,870	*1,870	*2,560	*2,560	1,640	1,330	1,070	890			900	750	4.55 m		
-2.0 m	kg	*2,900	*2,900	*3,240	2,630	1,670	1,360					1,230	1,020	3.69 m		

SK50SRX SK58SRX

SK58SRX Canopy		Arm: 1.69 m		Standard counterweight		Rubber shoe: 400 mm							
B	A	1.0 m	2.0 m	3.0 m	4.0 m	5.0 m	At Max. Reach		Radius				
	5.0 m	kg						*1,040	*1,040	3.38 m			
4.0 m	kg				*930	*930	970	820	4.48 m				
3.0 m	kg				*1,000	970	810	680	790	660	5.07 m		
2.0 m	kg			*1,620	1,430	1,120	930	790	670	710	590	5.37 m	
1.0 m	kg			1,630	1,320	1,070	880	770	640	680	570	5.44 m	
G.L.	kg		*1,260	*1,260	1,580	1,270	1,030	850	760	630	700	590	5.27 m
-1.0 m	kg	*2,080	*2,080	*2,590	2,470	1,580	1,270	1,020	840		790	660	4.86 m
-2.0 m	kg	*3,210	*3,210	*3,350	2,520	1,600	1,290	1,050	860		1,020	840	4.09 m
-3.0 m	kg		*1,580	*1,580							*1,190	*1,190	2.52 m

SK58SRX Cab		Arm: 1.69 m		Standard counterweight		Rubber shoe: 400 mm							
B	A	1.0 m	2.0 m	3.0 m	4.0 m	5.0 m	At Max. Reach		Radius				
	5.0 m	kg								*1,040	*1,040	3.38 m	
4.0 m	kg				*930	*930			*1,000	850	4.48 m		
3.0 m	kg				*1,000	970	810	680	790	660	5.07 m		
2.0 m	kg			*1,620	1,480	1,160	970	830	690	740	620	5.37 m	
1.0 m	kg			1,700	1,370	1,110	920	800	670	710	600	5.44 m	
G.L.	kg		*1,260	*1,260	1,650	1,320	1,080	890	790	660	730	610	5.27 m
-1.0 m	kg	*2,080	*2,080	*2,590	2,570	1,640	1,320	1,070	880		820	680	4.86 m
-2.0 m	kg	*3,210	*3,210	*3,350	2,620	1,670	1,340	1,090	900		1,060	870	4.09 m
-3.0 m	kg		*1,580	*1,580							*1,190	*1,190	2.52 m

SK58SRX Canopy		Arm: 1.92 m		Standard counterweight		Rubber shoe: 400 mm								
B	A	1.0 m	2.0 m	3.0 m	4.0 m	5.0 m	At Max. Reach		Radius					
	5.0 m	kg						*940	*940	3.77 m				
4.0 m	kg				*820	*820	880	740	4.75 m					
3.0 m	kg				*900	900	810	680	730	610	5.31 m			
2.0 m	kg			*1,430	*1,430	1,120	930	790	660	660	550	5.60 m		
1.0 m	kg			1,640	1,320	1,060	880	760	640	640	530	5.66 m		
G.L.	kg		*1,300	*1,300	1,570	1,260	1,020	840	750	620	650	540	5.50 m	
-1.0 m	kg	*1,820	*1,820	*2,360	*2,360	1,550	1,240	1,010	830	740	620	720	600	5.11 m
-2.0 m	kg	*2,790	*2,790	3,330	2,470	1,570	1,260	1,020	840		900	740	4.40 m	
-3.0 m	kg		*2,180	*2,180	*1,280	*1,280					*1,220	*1,220	3.07 m	

SK58SRX Cab		Arm: 1.92 m		Standard counterweight		Rubber shoe: 400 mm								
B	A	1.0 m	2.0 m	3.0 m	4.0 m	5.0 m	At Max. Reach		Radius					
	5.0 m	kg								*940	*940	3.77 m		
4.0 m	kg				*820	*820			920	770	4.75 m			
3.0 m	kg				*900	900	840	710	760	640	5.31 m			
2.0 m	kg			*1,430	*1,430	*1,130	970	820	690	690	570	5.60 m		
1.0 m	kg			1,700	1,370	1,110	910	800	660	660	550	5.66 m		
G.L.	kg		*1,300	*1,300	1,630	1,310	1,070	880	780	650	680	570	5.50 m	
-1.0 m	kg	*1,820	*1,820	*2,360	*2,360	1,620	1,290	1,050	860	770	640	750	620	5.11 m
-2.0 m	kg	*2,790	*2,790	3,460	2,570	1,640	1,310	1,070	870		940	780	4.40 m	
-3.0 m	kg		*2,180	*2,180	*1,280	*1,280					*1,220	*1,220	3.07 m	

SK58SRX Canopy		Arm: 1.69 m		Additional counterweight (+250 kg)		Rubber shoe: 400 mm							
B	A	1.0 m	2.0 m	3.0 m	4.0 m	5.0 m	At Max. Reach		Radius				
	5.0 m	kg						*1,040	*1,040	3.38 m			
4.0 m	kg				*930	*930	*1,000	920	4.48 m				
3.0 m	kg				*1,000	910	770	890	750	5.07 m			
2.0 m	kg			*1,620	1,610	*1,220	1,050	900	760	800	680	5.37 m	
1.0 m	kg			1,850	1,500	1,210	1,010	880	740	780	660	5.44 m	
G.L.	kg		*1,260	*1,260	1,790	1,450	1,170	970	860	720	800	680	5.27 m
-1.0 m	kg	*2,080	*2,080	*2,590	*2,590	1,790	1,450	1,170	970		900	750	4.86 m
-2.0 m	kg	*3,210	*3,210	*3,350	2,860	1,820	1,470	1,190	990		1,150	960	4.09 m
-3.0 m	kg		*1,580	*1,580							*1,190	*1,190	2.52 m

SK58SRX Cab		Arm: 1.69 m		Additional counterweight (+250 kg)		Rubber shoe: 400 mm							
B	A	1.0 m	2.0 m	3.0 m	4.0 m	5.0 m	At Max. Reach		Radius				
	5.0 m	kg								*1,040	*1,040	3.38 m	
4.0 m	kg				*930	*930			*1,000	950	4.48 m		
3.0 m	kg				*1,000	910	770	890	750	5.07 m			
2.0 m	kg			*1,620	*1,620	*1,220	1,090	930	780	830	700	5.37 m	
1.0 m	kg			1,910	1,550	1,250	1,040	910	760	810	680	5.44 m	
G.L.	kg		*1,260	*1,260	1,860	1,500	1,220	1,010	890	750	830	700	5.27 m
-1.0 m	kg	*2,080	*2,080	*2,590	*2,590	1,850	1,500	1,210	1,000		930	780	4.86 m
-2.0 m	kg	*3,210	*3,210	*3,350	2,960	1,880	1,520	1,230	1,020		1,200	990	4.09 m
-3.0 m	kg		*1,580	*1,580							*1,190	*1,190	2.52 m

SK58SRX Canopy		Arm: 1.92 m		Additional counterweight (+250 kg)		Rubber shoe: 400 mm								
B	A	1.0 m	2.0 m	3.0 m	4.0 m	5.0 m	At Max. Reach		Radius					
	5.0 m	kg						*940	*940	3.77 m				
4.0 m	kg				*820	*820	*930	840	4.75 m					
3.0 m	kg				*900	900	910	770	830	700	5.31 m			
2.0 m	kg			*1,430	*1,430	*1,130	1,050	890	750	750	630	5.60 m		
1.0 m	kg			1,850	1,500	1,200	1,000	870	730	730	610	5.66 m		
G.L.	kg		*1,300	*1,300	1,780	1,440	1,160	960	850	710	750	630	5.50 m	
-1.0 m	kg	*1,820	*1,820	*2,360	*2,360	1,770	1,420	1,150	950	850	710	820	690	5.11 m
-2.0 m	kg	*2,790	*2,790	*3,650	2,810	1,790	1,440	1,160	960		1,020	850	4.40 m	
-3.0 m	kg		*2,180	*2,180	*1,280	*1,280					*1,220	*1,220	3.07 m	

SK58SRX Cab		Arm: 1.92 m		Additional counterweight (+250 kg)		Rubber shoe: 400 mm								
B	A	1.0 m	2.0 m	3.0 m	4.0 m	5.0 m	At Max. Reach		Radius					
	5.0 m	kg								*940	*940	3.77 m		
4.0 m	kg				*820	*820			*930	870	4.75 m			
3.0 m	kg				*900	900	930	800	860	720	5.31 m			
2.0 m	kg			*1,430	*1,430	*1,130	1,090	930	780	780	660	5.60 m		
1.0 m	kg			1,920	1,550	1,250	1,040	900	760	750	630	5.66 m		
G.L.	kg		*1,300	*1,300	1,850	1,490	1,210	1,000	880	740	770	650	5.50 m	
-1.0 m	kg	*1,820	*1,820	*2,360	*2,360	1,830	1,480	1,190	990	880	740	860	720	5.11 m
-2.0 m	kg	*2,790	*2,790	*3,650	2,910	1,850	1,490	1,210	1,000		1,060	880	4.40 m	
-3.0 m	kg		*2,180	*2,180	*1,280	*1,280					*1,220	*1,220	3.07 m	

- Do not attempt to lift or hold any load that is greater than these lift capacities at their specified lift point radius and heights. Weight of all accessories must be deducted from the above lift capacities.
- Lift capacities are based on machine standing on level, firm, and uniform ground. User must make allowance for job conditions such as soft or uneven ground, out of level conditions, side loads, sudden stopping of loads, hazardous conditions, experience of personnel, etc.
- Arm top defined as lift point.
- The above lift capacities are in compliance with ISO 10567. They do not exceed 87% of hydraulic lift capacity or 75% of tipping load. Lift capacities marked with an asterisk(*) are limited by hydraulic capacity rather than tipping load.
- Operator should be fully acquainted with the Operator's and Maintenance Instructions before operating this machine. Rules for safe operation of equipment should be adhered to at all times.
- Lift capacities apply to only machine as originally manufactured and normally equipped by KOBELCO CONSTRUCTION MACHINERY CO., LTD.

Note: This catalogue may contain attachments and optional equipment that are not available in your area. And it may contain photographs of machines with specifications that differ from those of machines sold in your areas. Please consult your nearest KOBELCO distributor for those items you require.
Specialist equipment is needed to use this machine in demolition work. Before using it please contact your KOBELCO dealer.
Due to our policy of continuous product improvements all designs and specifications are subject to change without advance notice.
Copyright by **KOBELCO CONSTRUCTION MACHINERY CO., LTD.** No part of this catalogue may be reproduced in any manner without notice.

KOBELCO CONSTRUCTION MACHINERY EUROPE B.V.

Veluwezoom 15
1327 AE Almere
The Netherlands
www.kobelco-europe.com

Enquiries To: